



# SYED AMMAL ENGINEERING COLLEGE

Approved by the AICTE, New Delhi, Govt. of Tamilnadu and Affiliated to Anna University, Chennai)  
Established in 1998 - An ISO 9001:2008 Certified Institution  
Dr. E.M.Abdullah Campus, Lanthai, Ramanathapuram – 623 502.  
Phone: 304000, 304222, 304101 (04567)



Fax: 304123 (04567) Web: [www.syedengg.ac.in](http://www.syedengg.ac.in), E.mail:saec@syedengg.ac.in

## DEPARTMENT OF ELECTRONICS AND COMMUNICATION ENGINEERING

### MULTIMEDIA COMPRESSION AND COMMUNICATION

#### 1. What is rate distortion theory?

Rate distortion theory is concerned with the trade-offs between distortion and rate in lossy compression schemes. If the average number of bits used to represent each sample value i.e. the rate is decreased there will be an increase in distortion. This is rate distortion theory.

#### 2. Define the basic concepts of information theory.

If the probability of an event is low the amount of self information associated with it is high; i.e. the probability of an event is high, the information associated with it is low. The self information associated with any event is given by,

$$i(A) = -\log p(A).$$

#### 3. Write any three techniques for lossless compression?

Huffman coding.

Shannon fano coding.

Arithmetic coding.

#### 4. How entropy is related for the performance measures?

The entropy is a measure of the average number of binary symbols needed to code the o/p of the source. Hence for a compression scheme to be lossless it is necessary to code the o/p of the source with an average number of bits equal to the entropy of the source.

If the reconstructed data in the received end is same as that of the original data, then it is a lossless compression.

If the reconstructed data in the received end is differs from that of the original data, then it is a lossy compression.



# SYED AMMAL ENGINEERING COLLEGE

aid by the AICTE, New Delhi, Govt. of Tamilnadu and Affiliated to Anna University, Chennai)  
Established in 1998 - An ISO 9001:2008 Certified Institution  
Dr. E.M.Abdullah Campus, Lanthai, Ramanathapuram – 623 502.  
Phone: 304000, 304222, 304101 (04567)



Fax: 304123 (04567) Web: [www.syedengg.ac.in](http://www.syedengg.ac.in), E.mail:saec@syedengg.ac.in

## DEPARTMENT OF ELECTRONICS AND COMMUNICATION ENGINEERING

### 6. Write any three techniques for lossy compression?

- i) Subband coding
- ii) Wavelet based compression
- iii) JPEG

### 7. Define vector quantization and give its merit over scalar quantization.

If the set of inputs & outputs of a quantizer are vectors then it is called vector quantization. For a given rate the use of vector quantization results in a lower distortion than scalar quantization.

### 8. What are the important applications of data compression?

Data compression schemes find its application in mobile communication, digital TV, satellite TV.

### 9. Write the taxonomy of compression techniques?

Based on the requirements of reconstruction, data compression scheme can be classified as lossy compression and lossless compression.

### 10. What is meant by companded quantization?

In companded quantization the input is first mapped through a compressor function. This function stretches the high probability regions close to the origin and correspondingly compresses the low probability regions away from the origin. The output of the compressor function is quantized using a uniform quantizer & the quantized value is transformed via an expander function. This is known as companded quantization.

### 11. What is meant by modelling?

Modelling is nothing but extracting the information about any redundancy that exist in the data and describing the redundancy in the form of a model.



# SYED AMMAL ENGINEERING COLLEGE

Approved by the AICTE, New Delhi, Govt. of Tamilnadu and Affiliated to Anna University, Chennai)  
Established in 1998 - An ISO 9001:2008 Certified Institution  
Dr. E.M.Abdullah Campus, Lanthai, Ramanathapuram – 623 502.  
Phone: 304000, 304222, 304101 (04567)

Fax: 304123 (04567) Web: [www.syedengg.ac.in](http://www.syedengg.ac.in), E.mail:saec@syedengg.ac.in



## DEPARTMENT OF ELECTRONICS AND COMMUNICATION ENGINEERING

### 12. What are the parts of human audio visual system?

The various parts of a human audio visual system are retina, fovea, tympanic, membrane, cochlea, oval window etc.

### 13. Give some models that are used in lossless compression?

The various models that are used in a lossless compression scheme are probabilistic models, physical models, and markov models, composite source models etc.

### 14. Give some models that are used in a lossy compression.

The various models that are used in a lossy compression scheme are probabilistic models, physical models, and linear system models.

### 15. What is a composite source model?

In many applications, it is not easy to use a single model to describe the source. In such cases, we can define a composite source , with only one source being active at a time.

### 16. What are prefix codes?

A code in which no code word is a prefix to another code word is called prefix code (eg.Huffman code)

### 17. Give any two characteristics of a code.

- i) A code should be uniquely decodable.
- ii) The code words for letters that occur more frequently are shorter than for letters that occurs less frequently.



# SYED AMMAL ENGINEERING COLLEGE

Approved by the AICTE, New Delhi, Govt. of Tamilnadu and Affiliated to Anna University, Chennai)  
Established in 1998 - An ISO 9001:2008 Certified Institution  
Dr. E.M.Abdullah Campus, Lanthai, Ramanathapuram – 623 502.  
Phone: 304000, 304222, 304101 (04567)



Fax: 304123 (04567) Web: [www.syedengg.ac.in](http://www.syedengg.ac.in), E.mail:saec@syedengg.ac.in

## DEPARTMENT OF ELECTRONICS AND COMMUNICATION ENGINEERING

### 18. What are the two types of quantization error?

Granular error and slope over load error.

### 19. What are two types of adaptive quantization?

The two types of adaptive quantization are forward adaptive quantization and backward adaptive quantization.

### 20. What do you mean by forward adaptive quantization?

In forward adaptive quantization, the source output is divided into blocks of data. Each block is analyzed before quantization, and the quantizer parameters are set accordingly. The settings of the quantizer are then transmitted to the receiver as side information.

### 21. What is meant by optimum prefix codes?

- In an optimum code, symbols that occur more frequently (have a higher probability of occurrence) will have shorter code words than symbols that occur less frequently.
- In an optimum code, the two symbols that occur less frequently will have the same length.

### 22. Write any three techniques for loss less compression?

- a. Huffman coding
- b. Adaptive Huffman coding
- c. Arithmetic coding
- d. Shannonfano coding

### 23. What are the applications of Arithmetic coding?

- a. Bi-level Image compression-JBIG standard
- b. JBIG2
- c. Image compression



# SYED AMMAL ENGINEERING COLLEGE

Established by the AICTE, New Delhi, Govt. of Tamilnadu and Affiliated to Anna University, Chennai)  
Established in 1998 - An ISO 9001:2008 Certified Institution  
Dr. E.M.Abdullah Campus, Lanthai, Ramanathapuram – 623 502.  
Phone: 304000, 304222, 304101 (04567)  
Fax: 304123 (04567) Web: [www.syedengg.ac.in](http://www.syedengg.ac.in), E.mail:saec@syedengg.ac.in



## DEPARTMENT OF ELECTRONICS AND COMMUNICATION ENGINEERING

### 24. What does digram-coding mean?

- a. It is one of the most common forms of static dictionary coding.
- b. In this form of coding, the dictionary consists of all letters of the source alphabet followed by as many pairs of letters called digrams.
- c. The digram encoder reads two character input and search the dictionary to see if this input exists. If so, index is encoded and transmitted.

### 25.What is LZ family algorithm?

It is one of the widely used adaptive dictionary based technique.  
LZ77, LZ78, LZW are the different approaches in this algorithm.

### 26.Define offset in LZ77 approach?

To encode the sequence in the look ahead buffer, the encoder moves a search pointer back through the search buffer until it encounters a match to the first symbol I the look ahead buffer. The distance of the pointer from the look ahead buffer is called the offset.

### 27. Define search buffer and look ahead buffer?

The encoder examines the input sequence through a sliding window. The window consists of two parts, search buffer that contains a portion of the recently encoded sequence and a look ahead buffer that contains the next portion of the sequence to be encoded.

### 28.Give some application of LZW?



# SYED AMMAL ENGINEERING COLLEGE

Approved by the AICTE, New Delhi, Govt. of Tamilnadu and Affiliated to Anna University, Chennai)  
Established in 1998 - An ISO 9001:2008 Certified Institution  
Dr. E.M.Abdullah Campus, Lanthai, Ramanathapuram – 623 502.  
Phone: 304000, 304222, 304101 (04567)  
Fax: 304123 (04567) Web: [www.syedengg.ac.in](http://www.syedengg.ac.in), E.mail:saec@syedengg.ac.in



## DEPARTMENT OF ELECTRONICS AND COMMUNICATION ENGINEERING

- a. File compression-UNIX compression
- b. Image compression-GIF (Graphics Interchange Format)
- c. Compression over MODEMS-V.42 bits

### 29.What does Static Dictionary mean?

- d. Static dictionary are used when prior knowledge about the sources available.
- e. Depending on the input source the dictionary is adapted.

### 29. What is meant by adaptive dictionary?

- a. This is used in situation when there is no prior knowledge about the sources available.
- b. Depending on the input source the dictionary is adapted.

### 30. Is Huffman coding lossy or less compression?

Huffman coding is a loss less compression.

### 31. Give an example for offline encoding and online encoding?

- a. Huffman coding is a offline coding in which the data's are stored in a buffer and then encoded.
- b. Adaptive Huffman coding is an online encoding in which the input data coded directly by using tree encoding technique.

### 32. Define lexicographic ordering?

In lexicographic ordering the ordering of the letters in an alphabet induces an ordering on the words constructed from this alphabet. Ex:  
ordering of words in a dictionary.



# SYED AMMAL ENGINEERING COLLEGE

Approved by the AICTE, New Delhi, Govt. of Tamilnadu and Affiliated to Anna University, Chennai)  
Established in 1998 - An ISO 9001:2008 Certified Institution  
Dr. E.M.Abdullah Campus, Lanthai, Ramanathapuram – 623 502.  
Phone: 304000, 304222, 304101 (04567)  
Fax: 304123 (04567) Web: [www.syedengg.ac.in](http://www.syedengg.ac.in), E.mail:saec@syedengg.ac.in



## DEPARTMENT OF ELECTRONICS AND COMMUNICATION ENGINEERING

### 33. What is the algorithm used in JBIG?

- Progressive transmission algorithm
- Loss less compression algorithm.

### 34. What are the different approaches used in a adaptive dictionary technique?

- LZ77
- LZ78
- LZW

### 35. What is meant by progressive transmission?

In progressive transmission of an image, a low-resolution representation of the image is sent first. This low resolution requires only few bits to encode. The image is then updated or refined to the desired fidelity by transmitting more and more information.

### 38. Define lossless channel.

The channel described by a channel matrix with only one nonzero element in each column is called a lossless channel. In the lossless channel no source information is lost in transmission.

### 39. Define Deterministic channel

A channel described by a channel matrix with only one nonzero element in each row is called a deterministic channel and this element must be unity.

### 40. What is the important of sub band coding in audio compression?

In sub band coding the source output is separated into different bands of frequencies. This results in frequency bands with different characteristics. Thus we can



# SYED AMMAL ENGINEERING COLLEGE

Established by the AICTE, New Delhi, Govt. of Tamilnadu and Affiliated to Anna University, Chennai)  
Established in 1998 - An ISO 9001:2008 Certified Institution  
Dr. E.M.Abdullah Campus, Lanthai, Ramanathapuram – 623 502.  
Phone: 304000, 304222, 304101 (04567)

Fax: 304123 (04567) Web: [www.syedengg.ac.in](http://www.syedengg.ac.in), E.mail:saec@syedengg.ac.in



## DEPARTMENT OF ELECTRONICS AND COMMUNICATION ENGINEERING

choose the compression scheme most suited to that characteristic. It also helps to a variable bit allocation to the various frequency components depending upon the information content. This decreases the average number of bits required to code the source output.

### 41. What are the parameters used in silence compression?

Silence compression in sound files is the equivalent of run length coding on normal data files. The various parameters are

- A threshold value below which it can be considered as silence
- A special 'silence code' followed by a single byte that indicates how many consecutive silence codes are present
- A threshold to recognize the start of a run of silence. Only if we have sufficient bytes of silence we apply silence coding.

A parameter to indicate how many consecutive non-silence codes are needed, after a string of silence, so that we can declare the silence runs to be over.

### 42. List the various analysis / synthesis speech schemes.

The various analysis / synthesis schemes are

- Channel vocoders (each segment of input speech is analyzed using a bank of filters)
- Linear predictive vocoders (US govt. standard at the rate of 2.4Kbps)
- Code excited linear prediction (CELP) based schemes. [federal standard 1016 (FS-10), G.728 speech standard]
- Sinusoidal coders which provide excellent performance at rates of 4.8Kbps and
- Mixed excitation linear prediction (MELP), [which is the new standard 2.4Kbps federal standard speech coder].

### 43. What are the factors to be considered for a voiced/ unvoiced decision in predictive coders?

The following factors are considered

- Voiced speech (a/e/o) has larger amplitude and hence more energy than unvoiced signals(s/f)
- Unvoiced speech has higher frequencies. Hence the unvoiced crosses  $x=0$  line more often than voiced speech sample signals.
- Checking the magnitudes of the coefficients of the equivalent vocal tract filter.





# SYED AMMAL ENGINEERING COLLEGE

Established by the AICTE, New Delhi, Govt. of Tamilnadu and Affiliated to Anna University, Chennai)  
Established in 1998 - An ISO 9001:2008 Certified Institution  
Dr. E.M.Abdullah Campus, Lanthai, Ramanathapuram – 623 502.  
Phone: 304000, 304222, 304101 (04567)  
Fax: 304123 (04567) Web: [www.syedengg.ac.in](http://www.syedengg.ac.in), E.mail:saec@syedengg.ac.in



## DEPARTMENT OF ELECTRONICS AND COMMUNICATION ENGINEERING

Therefore we can decide about whether the speech is voiced or unvoiced based on the energy in the segment relative to background noise and the number of zero crossings within a specified window.

### 44. What are the components of MPEG audio scheme?

Moving Picture Expert Group (MPEG) has proposed three coding schemes called Layer1, Layer2, Layer3 coding. The coders are upward compatible. A layer N decoder is able to decode the bit stream generated by N-1 encoder.

Layer 1 & 2 coders both use a bank of 32 filters, splitting the input into 32 bands. Each band has a bandwidth of  $f_s/64$ , where  $f_s$  is the sampling frequency. Allowable sampling frequencies are 32, 000, 44, 100, 48,000 samples/sec.

The output of the sub band is quantized using a uniform quantiser. A variable length quantiser is used. The number bits are assigned based on the masking property of human ears. That is, if we have a large amplitude signal at one frequency, the audibility of the neighboring signals is affected. Hence if we have a large signal in one of the sub bands, we need only fewer bits to code a neighboring sub band.

### 45. Define vocoders and what are the types channel vocoders?

Vocoders are also called voice coders. Vocoders reproduce synthetic sounding which is somewhat artificial quality. They can transmit signals at a lower bit rate in the range of 1.2 to 2.4Kb. The receiver uses the model parameters along with the transmitted parameters to synthesize the approximation to the source output. The types of channel vocoders are linear predictive coder and code excited linear prediction.

### 46. What is known as quadrature mirror filter?

The filter bank in sub band coding consists of a cascade of filter stages where each stage consists of LPF & HPF. The most popular among the filter is QMF. These filters have the property that the impulse response of a LPF is given by  $h_n$ . Then the high pass impulse response is given by  $[(-1)^n h_{N-1-n}]$ .

$$[h_{N-1-n}] = h_n, n=0,1, \dots, (N/2)-1.$$

### 47. Application to speech coding G.722

G.722 provides a technique for wide band coding of speech signals that is based on sub band coding. They provide high quality speech at 64Kbps. The two other models used to encode the input are at 56 & 48Kbps. These two models are used when auxiliary channels are used.



# SYED AMMAL ENGINEERING COLLEGE

Established by the AICTE, New Delhi, Govt. of Tamilnadu and Affiliated to Anna University, Chennai)  
Established in 1998 - An ISO 9001:2008 Certified Institution  
Dr. E.M.Abdullah Campus, Lanthai, Ramanathapuram – 623 502.  
Phone: 304000, 304222, 304101 (04567)

Fax: 304123 (04567) Web: [www.syedengg.ac.in](http://www.syedengg.ac.in), E.mail:saec@syedengg.ac.in



## DEPARTMENT OF ELECTRONICS AND COMMUNICATION ENGINEERING

### 48. Define bit allocation?

The allocation of bits between the sub bands is an important design parameter. Different sub band contain different amounts of information. We need to allocate the available bits among the sub bands according to some measure of information. The bit allocation can have a significant impact in the quality of the final reconstruction especially when the information content of different bands is very different.

### 49. Give an example of bit allocation procedure in basic sub band coding?

Suppose we are decomposing the source output into four bands and we want a coding rate of 1 bit per sample. We can accomplish this by using 1 bit per sample for each of the four bands. Otherwise we could simply discard the output of two of the bands and use 2 bits per sample for the two remaining bands. Other way is to discard the output of three of the four filters and use 4 bits per sample to encode the output of the remaining filter.

### 50. What is meant by decimation & interpolation?

Suppose we have a sequence  $X_0, X_1, X_2, \dots$ , then we can divide the sequence into two sub sequences, i.e.,  $X_0, X_2, X_4, \dots$  &  $X_1, X_3, \dots$  where  $1/z$  corresponds to a delay of one sample and  $M$  denotes sub sampling by a factor of  $M$ . this sub sampling process is called down sampling or decimation. The original sequence can be recovered from the two down sampling by inserting zeros between consecutive samples of the sub sequences. This is called up sampling or interpolation.

### 51. The cutoff frequency for anti-aliasing filter is 7 KHz and 8 KHz. Give reasons.

Even though the speech output is sampled at 16,000 samples per second, the cutoff frequency for the anti-aliasing filter is 7 KHz. The reason is that the cutoff frequency for the anti-aliasing filter is not going to be sharp like that of the ideal low pass filter. Therefore, the highest frequency component in the filter output will be greater than 7 KHz.

### 52. How masking properties of the human ear used in reducing the number of bits in uniform quantiser?

If we have a large amplitude signal at one frequency, it affects the audibility of signals at other frequencies. In particular, a loud signal at one frequency may make quantization noise at other frequencies inaudible. Therefore, if we have a large signal in one of the sub bands, we can tolerate more



# SYED AMMAL ENGINEERING COLLEGE

Established by the AICTE, New Delhi, Govt. of Tamilnadu and Affiliated to Anna University, Chennai)  
Established in 1998 - An ISO 9001:2008 Certified Institution  
Dr. E.M.Abdullah Campus, Lanthai, Ramanathapuram – 623 502.  
Phone: 304000, 304222, 304101 (04567)  
Fax: 304123 (04567) Web: [www.syedengg.ac.in](http://www.syedengg.ac.in), E.mail:saec@syedengg.ac.in



## DEPARTMENT OF ELECTRONICS AND COMMUNICATION ENGINEERING

quantization error in the neighboring bands and use fewer bits. So number of bits can be reduced in uniform quantiser.

### **53. Generally, auto correlation function is used as a tool for obtaining the pitch period. But in linear predictive coders, AMDF is used. Why?**

Voiced speech is not exactly periodic which makes the maximum lower than we would expect from the periodic signal. Generally, a maximum is detected by checking the auto correlation value against the threshold. If the value is greater than the threshold, a maximum is declared to have occurred. When there is uncertainty about the magnitude of the maximum value, it is difficult to select a value for the threshold. Another problem occurs because of the interference due to other resonances in vocal tract. So Average Magnitude Difference Function (AMDF) is used.

### **54. What are formants? What are its properties?**

All frequency components of speech are equally important. As the vocal tract is a tube of non uniform cross section, it resonates at a number of different frequencies. These frequencies are called formants.

The formants values change with different sounds, but ranges in which it occurred can be identified. For example, the first formant occurs in the range 2000-800 Hz for a male speaker and in the range 250-1000 Hz for a female speaker.

### **55. What is regular pulse excitation coding?**

The Multi Pulse- Linear Prediction Coding (MP-LPC) algorithm was later modified. Instead of using excitation vectors in which the nonzero values are separated by an arbitrary number of zero values, they forced the nonzero values to occur at regularly spaced intervals. Furthermore, they allowed the nonzero values to be taken on a number of different values. This scheme is called regular pulse excitation (RPE) coding.

### **56. Define aliasing. What is anti-aliasing filter?**

Components with frequencies higher than half the sampling rate show up at lower frequencies. This is called aliasing.

In order to prevent aliasing, most systems that require sampling will contain an anti-aliasing filter that restricts the input to the sampler to be less than half the sampling frequency.



# SYED AMMAL ENGINEERING COLLEGE

Established by the AICTE, New Delhi, Govt. of Tamilnadu and Affiliated to Anna University, Chennai  
Established in 1998 - An ISO 9001:2008 Certified Institution  
Dr. E.M.Abdullah Campus, Lanthai, Ramanathapuram – 623 502.  
Phone: 304000, 304222, 304101 (04567)

Fax: 304123 (04567) Web: [www.syedengg.ac.in](http://www.syedengg.ac.in), E.mail:sacc@syedengg.ac.in



## DEPARTMENT OF ELECTRONICS AND COMMUNICATION ENGINEERING

### 57. Give the Nyquist rule.

If the highest frequency component of a signal is  $f_0$ , then we need to sample the at a frequency more than  $2f_0$  times per second. This result is known as the Nyquist theorem or Nyquist rule.

It can also be extended to signals that only have frequency components between two frequencies  $f_1$  and  $f_2$ . In order to recover the signal exactly, we need to sample the signal at a rate of at least  $2(f_2-f_1)$  samples per second.

### 58. What are filter coefficients?

The general form of the input-output relationships of the filter is given by

$$Y_n = \sum_{i=0}^N a_i X_{n-i} + \sum_{i=1}^M b_i Y_{n-i}$$

where the sequence  $\{X_n\}$  is the input to the filter, the sequence  $\{Y_n\}$  is the output from the filter, and the values  $\{a_i\}$  and  $\{b_i\}$  are called the filter coefficients.

### 59. What is FIR and IIR filters?

If the input sequence is a signal 1 followed by all 0s, the output sequence is called the impulse response of the filter.

If the filter coefficient  $b_i$  are all 0, then the impulse response will die out after  $N$  samples. These filters are called Finite Impulse Response (FIR) filters. The number  $N$  is sometimes called the number of taps in the filter.

If any of the  $b_i$  have non zero values, the impulse response can continue forever. Filters with non zero value for some of the  $b_i$  are called Infinite Impulse Response (IIR filters).

### 60. Define quad tree?

Quad tree is a portioning method in fractal compression. In this method we start by dividing up the image into maximum size range blocks. If a particular block does not have a satisfactory reconstruction we can divide it up in to 4 blocks. These blocks in turn can also if needed be



# SYED AMMAL ENGINEERING COLLEGE

Established by the AICTE, New Delhi, Govt. of Tamilnadu and Affiliated to Anna University, Chennai)  
Established in 1998 - An ISO 9001:2008 Certified Institution  
Dr. E.M.Abdullah Campus, Lanthai, Ramanathapuram – 623 502.  
Phone: 304000, 304222, 304101 (04567)  
Fax: 304123 (04567) Web: [www.syedengg.ac.in](http://www.syedengg.ac.in), E.mail:saec@syedengg.ac.in



## DEPARTMENT OF ELECTRONICS AND COMMUNICATION ENGINEERING

divided in to 4 blocks. This method of partitioning is called quad tree partitioning

### 61. In what way SPIHT is more efficient than EZW?

In EZW when entire sub tree is insignificant we transmit all coefficients in it with a zero tree root label  $zr$

The SPIHT algorithm uses partitioning of trees in such a manner that it tend to keep insignificant coefficients together in larger subsets.

### 62. What is massic transformation?

In fractal compression massic transformation adjusts the intensity and orientation of pixels in domain block.

### 63. What is progressive transmission?

In progressive transmission of an image a low resolution representation of image is sent first. This low-resolution representation requires very few bits to encode.

### 64. What is the difference in JPEG and JPEG 2000?

JPEG 2000 differs mainly by means of transform coding. In JPEG 2000 wavelets are used to perform decomposition of image. In JPEG DCT is used

### 65. What is fractal compression?

fractal compression is a lossy compression method used to



# SYED AMMAL ENGINEERING COLLEGE

Established by the AICTE, New Delhi, Govt. of Tamilnadu and Affiliated to Anna University, Chennai)  
Established in 1998 - An ISO 9001:2008 Certified Institution  
Dr. E.M.Abdullah Campus, Lanthai, Ramanathapuram – 623 502.  
Phone: 304000, 304222, 304101 (04567)  
Fax: 304123 (04567) Web: [www.syedengg.ac.in](http://www.syedengg.ac.in), E.mail:saec@syedengg.ac.in



## DEPARTMENT OF ELECTRONICS AND COMMUNICATION ENGINEERING

compress images using fractals. The method is best suited for photographs of natural scenes. fractal compression technique relies on the fact that in certain images parts of images resembles other part of same image.

### 66. What is EBCOT?

Embedded Block Coding with Optimized Truncation is a block coding scheme. It generates an embedded bit stream. It organizes bit stream in a succession of layers. Each layer corresponds to certain distortion level. With in each layer each block is coded with a variable number of bits. The partitioning of bits between blocks is obtained using a lagrangian optimization that dictates the partitioning. The quality of reproduction is proportional to no. of layers received.

### 67. What is a wavelet transform?

Wavelets are functions defined over a finite interval and having an average value of zero. Basic idea of wavelet transform is to represent any arbitrary function as a super position of a set of such wavelets or basic functions. These basic functions are obtained from a single prototype wavelet called mother wavelet by dilations or contractions and translations.

### 68. Define delta modulation

Delta modulation is the one-bit version of differential pulse code modulation.

### 69. Define adaptive delta modulation

The performance of a delta modulator can be improved significantly by making the step size of the modulator assume a time- varying form.



# SYED AMMAL ENGINEERING COLLEGE

Established by the AICTE, New Delhi, Govt. of Tamilnadu and Affiliated to Anna University, Chennai)  
Established in 1998 - An ISO 9001:2008 Certified Institution  
Dr. E.M.Abdullah Campus, Lanthai, Ramanathapuram – 623 502.  
Phone: 304000, 304222, 304101 (04567)

Fax: 304123 (04567) Web: [www.syedengg.ac.in](http://www.syedengg.ac.in), E.mail:sacc@syedengg.ac.in



## DEPARTMENT OF ELECTRONICS AND COMMUNICATION ENGINEERING

In particular, during a steep segment of the input signal the step size is increased. Conversely, when the input signal is varying slowly, the step is reduced. In this way, the step size is adapting to the level of the signal. The resulting method is called adaptive delta modulation (ADM).

### 70. Name the types of uniform quantizer?

Mid tread type quantizer.

Mid riser type quantizer.

### 71. Define mid tread quantizer?

Origin of the signal lies in the middle of a tread of the

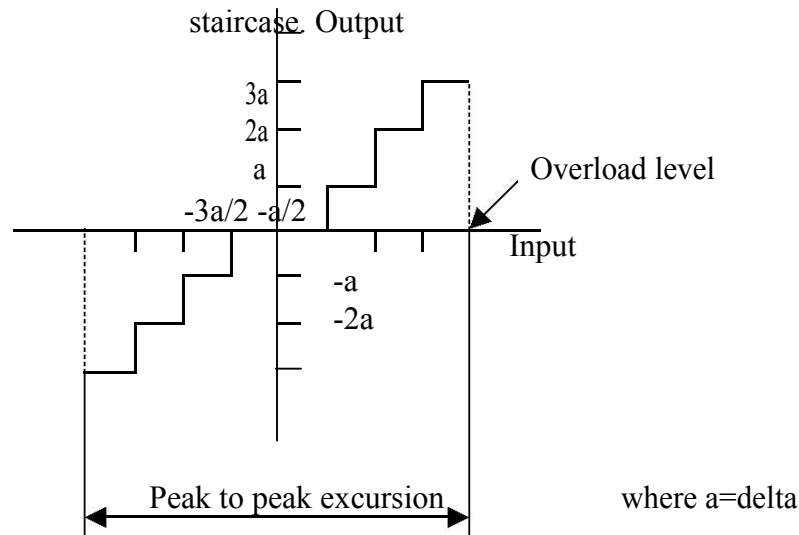

### 72. Define quantization error?

Quantization error is the difference between the output and input values of quantizer.





# SYED AMMAL ENGINEERING COLLEGE

Established by the AICTE, New Delhi, Govt. of Tamilnadu and Affiliated to Anna University, Chennai  
Established in 1998 - An ISO 9001:2008 Certified Institution  
Dr. E.M.Abdullah Campus, Lanthai, Ramanathapuram – 623 502.  
Phone: 304000, 304222, 304101 (04567)



Fax: 304123 (04567) Web: [www.syedengg.ac.in](http://www.syedengg.ac.in), E.mail:saec@syedengg.ac.in

## DEPARTMENT OF ELECTRONICS AND COMMUNICATION ENGINEERING

### 73. Define mid-riser quantizer?

Origin of the signal lies in the middle of a riser of the staircase

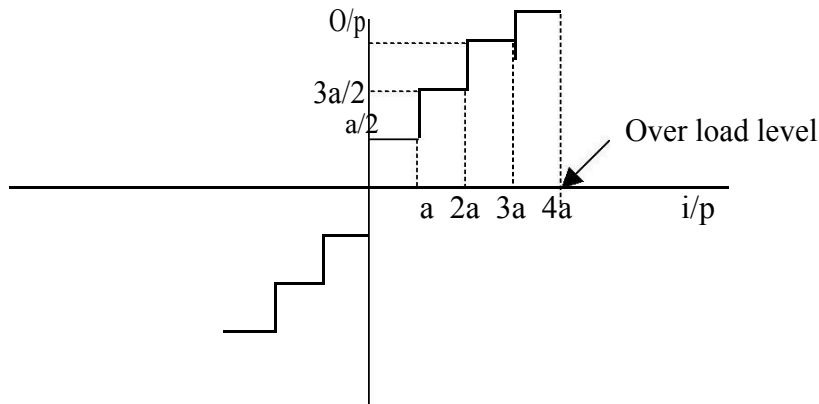

### 74. Draw the quantization error for the mid tread and mid-rise type of quantizer?

For mid tread type:

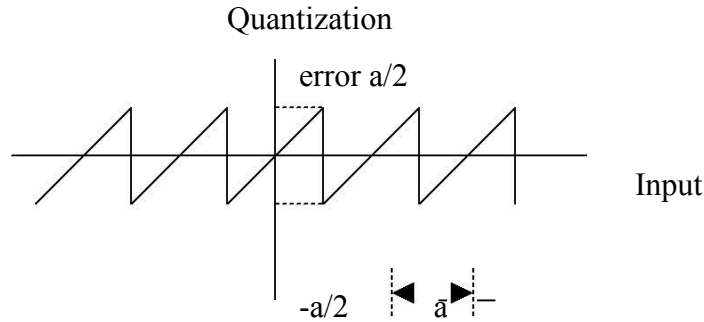

For mid riser type:

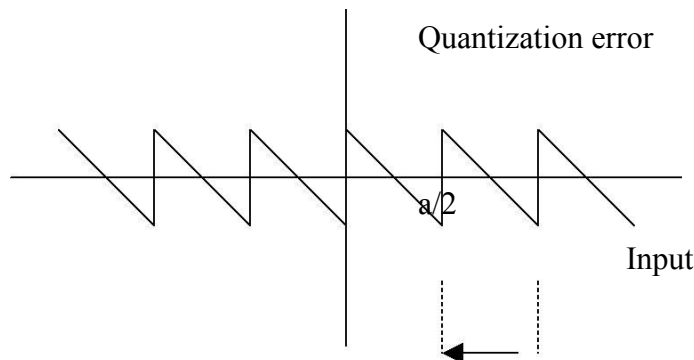





# SYED AMMAL ENGINEERING COLLEGE

Established by the AICTE, New Delhi, Govt. of Tamilnadu and Affiliated to Anna University, Chennai  
Established in 1998 - An ISO 9001:2008 Certified Institution  
Dr. E.M.Abdullah Campus, Lanthai, Ramanathapuram – 623 502.  
Phone: 304000, 304222, 304101 (04567)

Fax: 304123 (04567) Web: [www.syedengg.ac.in](http://www.syedengg.ac.in), E.mail:saec@syedengg.ac.in



## DEPARTMENT OF ELECTRONICS AND COMMUNICATION ENGINEERING

### 75.What you mean by non-uniform quantization?

Step size is not uniform. Non uniform quantizer is characterized by a step size that increases as the separation from the origin of the transfer characteristics is increased. Non-uniform quantization is otherwise called as *robust quantization*

### 76. What is the disadvantage of uniform quantization over the non-uniform quantization?

SNR decreases with decrease in input power level at the uniform quantizer but non-uniform quantization maintain a constant SNR for wide range of input power levels. This type of quantization is called as robust quantization.

### 77.What is video compression?

Video compression can be viewed as the compression of a sequence of images; in other words image compression with temporal component. Here the video compression makes use of temporal correlation to remove redundancy

### 78.What is motion compensation?

The previous reconstructed frame is used to generate a prediction for the current frame, the prediction error or residual, is encoded and transmitted to the receiver. The previous reconstructed frame is also available at the receiver. So the receiver knows the manner in which the prediction was performed, it can use this information to generate the



# SYED AMMAL ENGINEERING COLLEGE

Established by the AICTE, New Delhi, Govt. of Tamilnadu and Affiliated to Anna University, Chennai)  
Established in 1998 - An ISO 9001:2008 Certified Institution  
Dr. E.M.Abdullah Campus, Lanthai, Ramanathapuram – 623 502.  
Phone: 304000, 304222, 304101 (04567)

Fax: 304123 (04567) Web: [www.syedengg.ac.in](http://www.syedengg.ac.in), E.mail:saec@syedengg.ac.in



## DEPARTMENT OF ELECTRONICS AND COMMUNICATION ENGINEERING

prediction values and add them to the prediction error to generate the reconstruction. This prediction operation in video coding has taken to account the motion of objects in frame, which is known as motion compensation

### 79.What are the disadvantages of video compression?

We do not perceive the motion video in the same manner as we perceive the still images. Motion video may mask coding artifacts that would be visible in still images. On the other hand artifacts that may not be visible in reconstructed still images can be very annoying in the reconstructed motion video sequences

### 80.What is the advantage of loop filter?

Sharp edges in the block used for prediction can result in generation of sharp changes in the prediction error. This in turn causes high values for high frequency coefficients in transforms, which can increase transmission rate. To avoid this prior to taking the difference, the prediction block can be smoothed by using a two dimensional spatial filter. The filter is separable, it can be implemented as a one dimensional filter that first operates on rows and then on columns. The filter coefficients are  $\frac{1}{4}$ ,  $\frac{1}{2}$ ,  $\frac{1}{4}$ , except at block boundaries where one of the filter taps would fall outside block

### 81.Differentiate global motion & local motion?

In three dimensional model based approach to compression of facial image sequences, a generic wire frame model is constructed using triangles. Once this model is available to both transmitter and receiver, only changes in faces are transmitted to receiver. These changes can be classified as



# SYED AMMAL ENGINEERING COLLEGE

Established by the AICTE, New Delhi, Govt. of Tamilnadu and Affiliated to Anna University, Chennai  
Established in 1998 - An ISO 9001:2008 Certified Institution  
Dr. E.M.Abdullah Campus, Lanthai, Ramanathapuram – 623 502.  
Phone: 304000, 304222, 304101 (04567)

Fax: 304123 (04567) Web: [www.syedengg.ac.in](http://www.syedengg.ac.in), E.mail:saec@syedengg.ac.in



## DEPARTMENT OF ELECTRONICS AND COMMUNICATION ENGINEERING

global motion or local motion. global motion involves movement of head while local motion involves changes in features i.e. changes in facial expression.

### 82.What is MPEG-4?

The standard views a multimedia scene as a collection of objects. These objects can be visual such as still background or a talking head such as music, speech and so on. Each of these objects can be coded independently using different techniques to generate separate elementary bit streams. These bit streams are multiplexed along with a scene description. the protocol for managing the elementary streams and their multiplexed version called DELIVERY MULTIMEDIA INTEGRATION FRAME WORK is an important part of MPEG-4

### 83. What is H.261 standard?

The earliest DCT based video coding standard is H.261 standard. An i/p image is divided in to blocks of 8\*8 pixels. For a given 8\*8 pixel we subtract the prediction generated using the previous frame. The difference btw the block being encoded and the prediction is transformed using a DCT. The transform coefficients are quantized and the quantization label encoded using a variable length code.

### 84. What is MPEG?

Standards for asymmetric applications have been developed by ISO & IEC, which is known as MPEG. MPEG was set up at different rates for applications that require storage of audio and video on digital storage media. MPEG1 MPEG2& MPEG3 are targeted at rates of 1.5, 10,40Mb/s. respectively.



# SYED AMMAL ENGINEERING COLLEGE

Established by the AICTE, New Delhi, Govt. of Tamilnadu and Affiliated to Anna University, Chennai)  
Established in 1998 - An ISO 9001:2008 Certified Institution  
Dr. E.M.Abdullah Campus, Lanthai, Ramanathapuram – 623 502.  
Phone: 304000, 304222, 304101 (04567)

Fax: 304123 (04567) Web: [www.syedengg.ac.in](http://www.syedengg.ac.in), E.mail:saec@syedengg.ac.in



## DEPARTMENT OF ELECTRONICS AND COMMUNICATION ENGINEERING

### 85. List out one application of wavelet based computation?

One of the most popular applications of wavelet has been to image compression. The JPEG2000 standard is designed to update and replace the current JPEG standard will use wavelets instead of DCT to perform decomposition of image.

### 86. What is a mother wavelet?

The functions that are obtained by changing the size if function or scaling and translating the single function are called mother wavelet.

### 87. What is group of pictures?

Different frames like B frames, I frames, P frames are organized together in a group . This group is called as group of pictures. Group of pictures is a small random access unit in the video sequence.

### 88. Give the different orders in MPEG1 standarad.

Display order and bitstream order

Display order is the sequence in which video sequence is displayed to the user

Bitstream order is the processing order that is different from the display order.



# SYED AMMAL ENGINEERING COLLEGE

aid by the AICTE, New Delhi, Govt. of Tamilnadu and Affiliated to Anna University, Chennai)  
Established in 1998 - An ISO 9001:2008 Certified Institution  
Dr. E.M.Abdullah Campus, Lanthai, Ramanathapuram – 623 502.  
Phone: 304000, 304222, 304101 (04567)

Fax: 304123 (04567) Web: [www.syedengg.ac.in](http://www.syedengg.ac.in), E.mail:saec@syedengg.ac.in



## DEPARTMENT OF ELECTRONICS AND COMMUNICATION ENGINEERING

### 89. What is constrained parameter bitstream?

The MPEG committee has provided some suggested values for the various parameters like vertical picture size ,horizontal picture size ,pixel rate.These suggested values are called constrained parameter bitstream.

### 90. What do you meant by profiles and levels in MPEG 2 standard?

Profile defines the algorithm that is used in MPEG 2 standard and levels defines the constraints on the parameters.

### 91. Name the profiles and levels used in MPEG 2 standard.

Profiles are simple, main, snr-scalable, spatially scalable, and main. The levels are low, main, high 1440 and high.

The low level corresponds to a frame size of 352 x

240 The main level corresponds to a frame size of 720

x 480

The high 1440 level corresponds to a frame size of 1440 x

1152 The high level corresponds to a frame size of 1920 x

1080

### 92. What is DMIF?

DMIF means Delivery Multimedia Integration Framework. It is a protocol for managing the elementary bit streams and multiplexed version of different bit streams. It is used in MPEG 4 standard.



# SYED AMMAL ENGINEERING COLLEGE

aid by the AICTE, New Delhi, Govt. of Tamilnadu and Affiliated to Anna University, Chennai)  
Established in 1998 - An ISO 9001:2008 Certified Institution  
Dr. E.M.Abdullah Campus, Lanthai, Ramanathapuram – 623 502.  
Phone: 304000, 304222, 304101 (04567)

Fax: 304123 (04567) Web: [www.syedengg.ac.in](http://www.syedengg.ac.in), E.mail:saec@syedengg.ac.in



## DEPARTMENT OF ELECTRONICS AND COMMUNICATION ENGINEERING

### 93. What is a post detection filter?

The post detection filter named as” base-band low pass filter” has a bandwidth that is just large enough to accommodate the highest frequency component of the message signal.

### 94. What is the disadvantage of uniform quantization over the non-uniform quantization?

SNR decreases with decrease in input power level at the uniform quantizer but

non-uniform quantization maintain a constant SNR for wide range of input power levels. This type of quantization is called as robust quantization.

### 95. What are the two fold effects of quantizing process.

The peak-to-peak range of input sample values subdivided into a finite set of decision levels or decision thresholds .The output is assigned a discrete value selected from a finite set of representation levels are reconstruction values that are aligned with the treads of the staircase.

### 96. What is meant by idle channel noise?

Idle channel noise is the coding noise measured at the receiver output with zero transmitter input.

### 97.What are the applications of Huffman coding?

- Image compression
- Audio compression
- Text compression



# SYED AMMAL ENGINEERING COLLEGE

aid by the AICTE, New Delhi, Govt. of Tamilnadu and Affiliated to Anna University, Chennai)

Established in 1998 - An ISO 9001:2008 Certified Institution

Dr. E.M.Abdullah Campus, Lanthai, Ramanathapuram – 623 502.

Phone: 304000, 304222, 304101 (04567)

Fax: 304123 (04567) Web: [www.syedengg.ac.in](http://www.syedengg.ac.in), E.mail:saec@syedengg.ac.in



## DEPARTMENT OF ELECTRONICS AND COMMUNICATION ENGINEERING

### 98. What is forward and backward adaption?

In forward adaption, adaption is done before encoder. Decoder doesn't know about manipulation done.

In backward adaption, adaption is done after encoder. here decoder knows about manipulation done

### 99. What are the applications of MPEG-7?

Digital libraries-This include video libraries, image catalogs, musical dictionaries, future home multimedia databases.

Multimedia directory services-An examples are yellow pages.

Broadcast media selection-This includes radio channel and Internet broadcast search and selection.

Multimedia editing-personalized electronic news services and media Authoring

### 100.Describe the aims of MPEG-21

To understand if and how various components fit together

To discuss which new standards may be required, if gaps in the infrastructure exist and when the above two points have been reached.To accomplish the integration of different standards.